

Magnetic Field: The space or region around a magnet (or a current Carrying wire) with in which its influence can be felt or magnetic force can be felt by another magnet is called magnetic field. The direction of magnetic field at a point is the direction of the resultant force acting on a hypothetical North Pole placed at that point.

When a magnetic compass is brought close to a magnet, the needle is deflected. So the space or region around a magnet within which a magnetic compass is deflected is known as the magnetic field of the bar magnet.

Magnetic Lines Of Force: do not actually exist but are imaginary lines used to illustrate and describe the pattern of the magnetic filed. The magnetic lines of force are assumed to emanate from the north pole of a magnet, pass through surrounding space and enter the South Pole. The lines of forced then travel in side the magnet from the South Pole to the north. Thus, completing a closed loop.

Plotting Of Magnetic Field Lines of a bar Magnetic: to draw magnetic field of a magnet by magnetic compass, place a magnetic on a sheet of paper. Now bring the magnetic compass near the north pole of a magnet. The S pole will point towards N of the magnet. Mark the position of its two ends with the help of a sharp pencil. Now move the compass so that its south end occupies the position previously occupied by the north end. Mark the new positions indicated by the needle's end. Proceed stepwise till you reach South Pole of magnet. Join these to get lines of force.

Properties of Magnetic Field Lines:

1. A magnetic fields lines is directed from north-pole to south- pole outside the magnet.
2. A magnetic fields line is a closed and continuous curve. (we have not shown magnetic field lines inside the magnet where these are directed from south pole to north).
3. The magnetic field lines are crowded near the pole where the magnetic fields is strong and are far apart near the middle of the magnetic and far from the magnetic where the magnetic field is weak.
4. The magnetic field lines never intersect each other because if they do so, there would be two directions of magnetic field at that point which is absurd.
5. In case the field lines are parallel and equidistant, these represent a uniform magnetic field. The earth's magnetic field is uniform in a limited space.

Types of Magnetic Fields:

Uniform Magnetic Field: Magnetic fields is said to be uniform if its magnitude is equal and direction is same at every point in the space.

Uniform magnetic field is represented by equi-distant parallel straight lines as shown in figure.

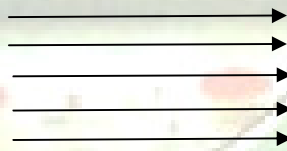

Uniform magnetic field.

Non-Uniform magnetic field: Magnetic field is said to be non-uniform magnetic field if its magnetic is not equal and direction is not same at every point in the space. Non-uniform magnetic field is represented as shown in figure.

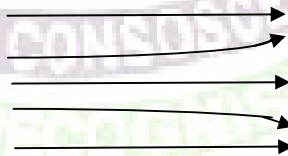

Non-Uniform magnetic field.

Domestic wiring or House hold electric circuits: The electric current is transmitted from PowerStation to houses through copper wires fixed over electric poles. From electric poles every house brings two insulated wires, one called live wire “L” having high potential of 220 Volts and the other Neutral wire “N” having a ground potential of zero Volts. Thus, the potential difference between two wires is 220 volts. The two insulated wires then enter a box having a fuse of high rating about 50 amperes called the main fuse “F₁” and a watt-hour meter “M”. Which records the

consumption of electrical energy in the units of Kilowatt hours? The two wires coming out from the meter are connected to a main switch “S”. After the main switch there is another fuse in the live wire called as consumers fuse “F₂”. The circuit is then divided into two separate circuits *lighting circuit* with a 5 ampere fuse and *power circuit* with a 15 ampere fuse. These fuses are provided separately, so as to detect any fault occurring in the circuit. However, a third wire, called as earth wire “E” is introduced into the heating or power circuit along with the live and neutral wires. The earth is an uncovered wire, whose one end is connected to a copper plate buried deep under the earth. In each room, all the electrical appliances like bulbs, fans, sockets etc. are provided with separate switches connected in parallel across the live wire and the neutral wires as shown under:

Usually, a red coloured wire is used as a live wire, a black wire as a neutral wire and a green wire as the earth wire. The separate coloured wires are used so as to make easy differentiation of live, neutral and earth wires.

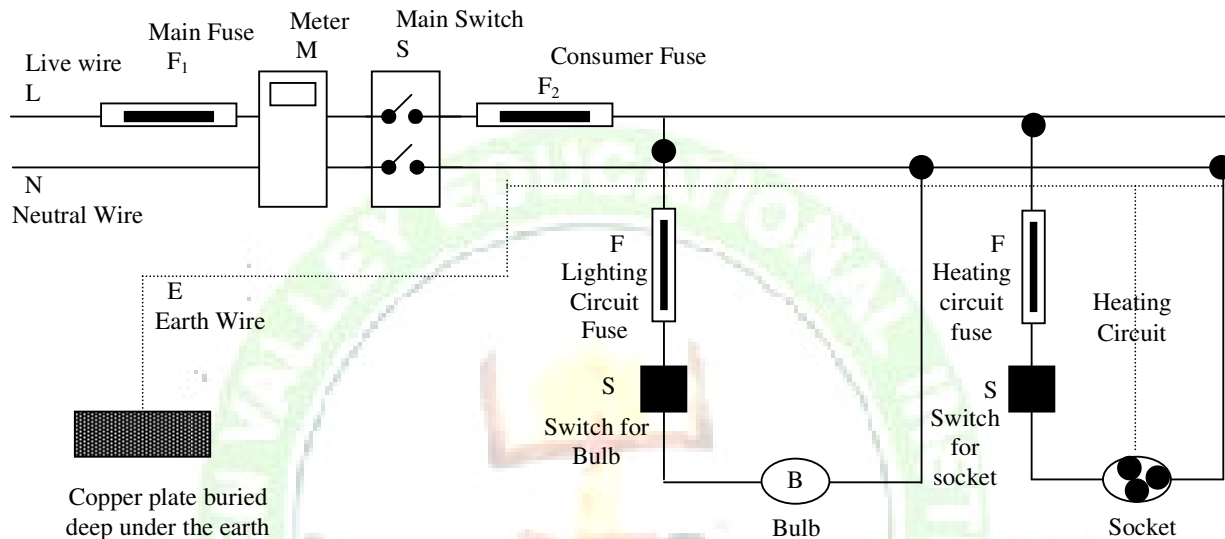

Hazards or Dangers of Electricity:

1. It gives a severe electric shock to a person touching it, which may prove fatal to the person.
2. Short circuiting due to damaged wiring or overloading can lead to over heating of the wires or even electrical fires causing great loss to property and life.
3. Fluctuations produced due to over loading may cause damage to various electrical appliances used in houses.
4. Defective switches, loose connections and wiring in circuits may cause sparking and lead to electrical fires.

Precautions in using electricity:

1. The electrical supply should be switched off or cut off incase of electric fires, short circuiting or any other electrical accident.
2. The electrical supply should be switched off incase a person receive an electric shock and should be ensured an insulated support of wood, plastic, rubber, cloth etc.
3. The wires of the circuits should be of good quality having a proper insulation, and the connections should be tight and properly covered with an insulating material.
4. While working with live circuits, rubber gloves and shoes should be used.
5. The electrical appliances should be properly connected to earth wire, so as to avoid electric shocks.

Electromagnetism: In 1820, Oersted performed an experiment to show that a current flowing through a wire produces a magnetic field around it. In this experiment, he found that when a magnetic needle was placed under a wire having no current flowing through it, the needle remained parallel to the wire as shown in the figure. But when electric current was allowed to flow through it by connecting it with a battery, a deflection was observed in the magnetic needle showing that a current carrying wire produces a magnetic field around it, which lasts as long as the current is flowing through the wire. This phenomenon is referred to as electromagnetism.

Magnetic Field Due To A Current Carrying Conductor :

Oersted performed an experiment to show that a magnetic field is set up around a current carrying conductor. The experiment was performed as follows :

1. Electricity current was allowed to pass through a metallic wire AB, placed parallel to the axis of a magnetic compass kept directly below the wire. The needle of the magnetic compass was found to deflect from its normal position as shown in figure.

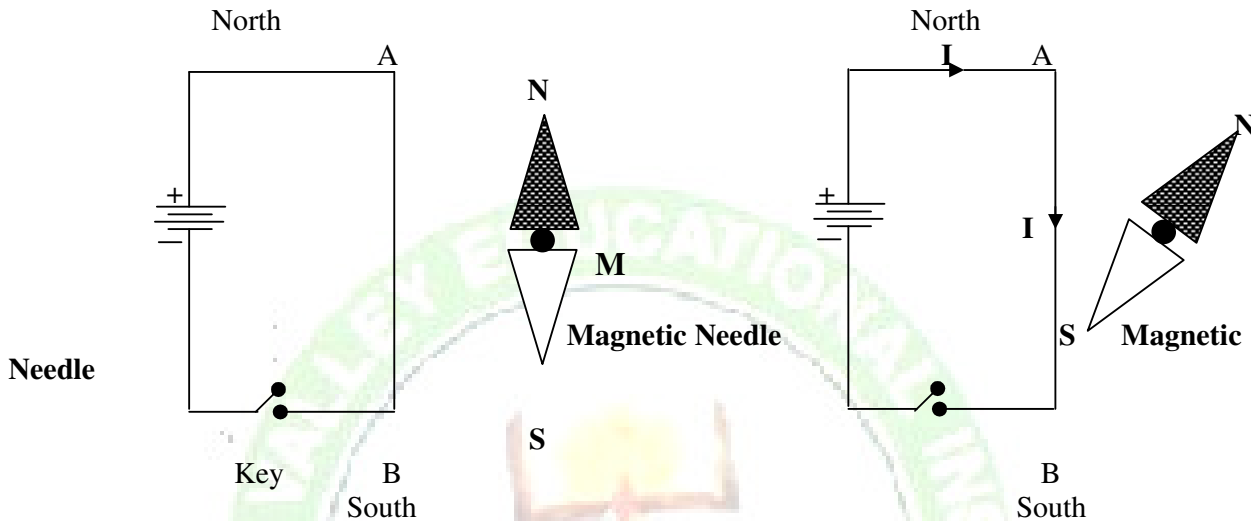

Diagram showing that magnetic needle is parallel

Diagram showing deflection in magnetic needle

2. Electric current was again allowed to pass through the same wire AB but now in opposite direction. It was found that the needle of the magnetic compass again deflected from its normal position in opposite direction as shown in figure (b).

These observations led Oersted to conclude that there must be a magnetic effect around the wire carrying electric current which deflected the magnetic compass.

MAGNETIC FIELD DUE TO A CURRENT THROUGH A STRAIGHT CONDUCTOR :

When a straight conductor carries electric current (dc), a magnetic field is set up around the conductor. This magnetic field causes the deflection in the needle of the magnetic compass. To show the magnetic field due to straight conductor carrying current, we perform the following experiment.

1. Take the thick piece of wire consisting of ten turns of insulated copper wire and a card board.
2. Pass this thick wire through a hole in the card board placed horizontally.
3. Now pass electric current (about 4A) through the wire by pressing the key and sprinkle some iron filings on the card board around wire.
4. Tap the card board gently.

Observation : we find that the iron filings would set in concentric circles around the wire.

Factors on which the intensity (or strength) of the magnetic field due to a current carrying conductor depends

1. **The amount of current flowing through a Conductor :** if current flowing through a conductor is increased with the help of a rheostat, then the deflection of the needle of the magnetic compass placed near the conductor (or wire) also increases. On the other hand, if current flowing through the conductor is decreased, then the deflection of the needle of the magnetic compass placed near the conductor also decreases. This shows that the strength of the magnetic field due to a current carrying conductor is directly proportional to the amount of current flowing through it. That is,

$$B \propto I$$

2. **Distance (r) from the Conductor :** As the distance of the magnetic compass from the current carrying conductor increases, the deflection of the needle of the magnetic

compass decreases. This shows that the strength of the magnetic field due to the current carrying conductor decreases with the increase of the distance. Thus, the strength of the magnetic field due to a current carrying conductor is inversely proportional to the distance from the conductor. That is,

$$B \propto \frac{1}{r}$$

The direction of the magnetic field around a conductor carrying current can be determined by Right Hand Thumb Rule.

Right Hand Thumb Rule :

If a current carrying conductor is imagined to be held in the right hand such that the thumb points in the direction of the current, then the curled fingers of the hand indicate the direction of magnetic field. If current in a conductor flows in the upward direction, then the direction of magnetic field around the conductor will be in anticlockwise direction. On the other hand, if current in a conductor flows in the downward direction, then the direction of the magnetic field around the conductor is in clockwise direction.

Magnetic Field due to a Current in a Solenoid :

A solenoid is a coil of many turns of an insulated copper wire closely wound in the shape of a tight spring.

Or

A solenoid is a long, helically wound coil of insulated copper wire. When an electric current flows through a solenoid, a magnetic field is set up which is similar to the magnetic field of a bar magnet. One end of the solenoid acts as South Pole and the other end acts as North Pole. If the current flows in a clockwise direction when the coil is seen end-on, then that end of the solenoid acts as a South Pole. On the other hand, if the current flows in anticlockwise direction when the coil is seen end-on, then that end of the solenoid acts as a North Pole.

Thus, face or end B of the solenoid behaves as South Pole and face or end A of the solenoid behaves as North Pole. In other words, a current carrying solenoid behaves as a bar magnet.

It may be noted that :

- (i) Magnetic field inside a long solenoid is uniform and strong.
- (ii) Magnetic field inside a long solenoid decreases as we move towards the ends of the solenoid because magnetic field lines near the ends of the solenoid start spreading out.
- (iii) Magnetic field outside the solenoid is non-uniform.
- (iv) Magnetic lines of force inside the solenoid are from South Pole to North Pole and outside the solenoid, these lines of force are from North Pole to South Pole.
- (v) The magnetic field of the solenoid resembles the magnetic field of the bar magnet.

MAGNETIC FIELD DUE TO A CURRENT-CARRYING CIRCULAR COIL :

Ampere found that a loop of wire also had a magnetic field. In order to find the magnetic field due to a coil, it is held in a vertical plane and is made to pass through a smooth cardboard in such a way that the centre (O) of the coil lies at the cardboard. A current is passed through the coil and iron filings are sprinkled on the cardboard. These iron filings arrange themselves in a pattern. This pattern represents the magnetic field lines due to the coil.

From this pattern, the following important conclusions have been drawn.

- 1) ***The magnetic field lines near the coil are nearly circular and concentric.*** This is due to the reason that the segments of the coil in contact with the board at the points A and B are almost like straight conductors. The direction of the field lines can also be found by applying Right-Hand Thumb Rule.
- 2) ***The field lines are in the same direction in the space enclosed by the coil.***
- 3) Near the centre of the coil, the field lines are nearly straight and parallel. As such ***the magnetic fields at the centre of the coil can be taken to be uniform.***
- 4) The direction of the magnetic field at the centre is perpendicular to the plane of the coil.

- 5) As we move towards the centre of the coil, the strength of magnetic field increases. **Magnetic field is maximum at its centre.** This is due to the reason that the two magnetic fields (one due to the semicircular segment of the coil through A and the other due to the semicircular segment through B) assist each other.

MAGNITUDE (B) OF MAGNETIC FIELD :

The magnitude of the magnetic field (B) at the centre of the coil is :

- 1) Directly proportional to the current (I) flowing through it, i.e.,

$$B \propto I$$

- 2) Inversely proportional to the radius (r) of the coil, i.e.,

$$B \propto \frac{1}{r}$$

- 3) Directly proportional to the total number of turns (N) in the coil, i.e.,

$$B \propto N$$

This is due to the reason that the current in all the circular turns of the coil is in the same direction. As such, the resultant magnetic field due to the coil is equal to the sum of the fields due to all these turns. Combining (1), (2) and (3), we obtain

$$B \propto \frac{NI}{r}$$

Electromagnet: An electromagnet consists of a long coil of insulated copper wire wound around a soft iron core. It works on the magnetic effect of current. It acts as a temporary magnet as long as electric current flows through the coil, the moment an electric current is stopped; the coil loses its magnetism. An electromagnet has various shapes and sizes and its strength depends upon the number of turns in the coil, magnitude of current and length of air gaps between its poles.

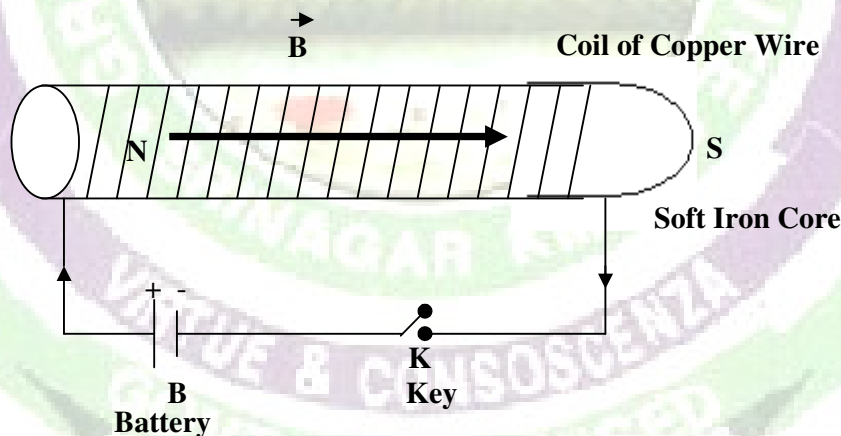

Factors effecting strength of an electromagnet: The various factors which effect the strength of an electromagnet are:

- i) The increase in the no. of turns in the coil of an electromagnet increases its strength.
- ii) Increasing the current flowing through the coil, increase the strength of an electromagnet.
- iii) Decreasing the length of air gaps between the poles increases the strength of an electromagnet.

USES OF ELECTROMAGNETS :

1. Electromagnets are used in electrical devices such as an electric bell, an electric fan, telegraph, an electric train, an electric motor, generator etc.
2. For lifting and transporting large masses of iron in the form of girders.
3. In medical practice for removing pieces iron from wounds.

Electromagnetic Induction: In 1831, Michael Faraday found that when a straight metal wire is moved up and down in a magnetic field between the poles of a horse-shoe magnet, an electric current is produced in the wire. This process of production of electric current by moving a straight wire in a magnetic field is called as

Electromagnetic induction and the current produced as **induced current**. The production of induced current

Continues as long the relative motion between the wire and the magnetic field continues. The moment the relative motion is stopped, the production of magnetic current also stops.

Experimental demonstration: Consider a metal wire “AB” held between the N and S of a permanent horse-shoe type magnet “M”. The two ends of the wire are connected to a galvanometer “G”. When the wire is held stationary i.e., there is no relative motion between the wire and the magnet, no deflection is observed in the galvanometer indicating that no current is produced. But when the wire is moved downwards, there is a deflection in the galvanometer, pointer showing presence of current in the wire and when the wire is moved upwards, the galvanometer again shows deflection but in the opposite direction. This shows that when the direction of motion of the wire in the magnetic field is reversed, the direction of induced current also gets reversed.

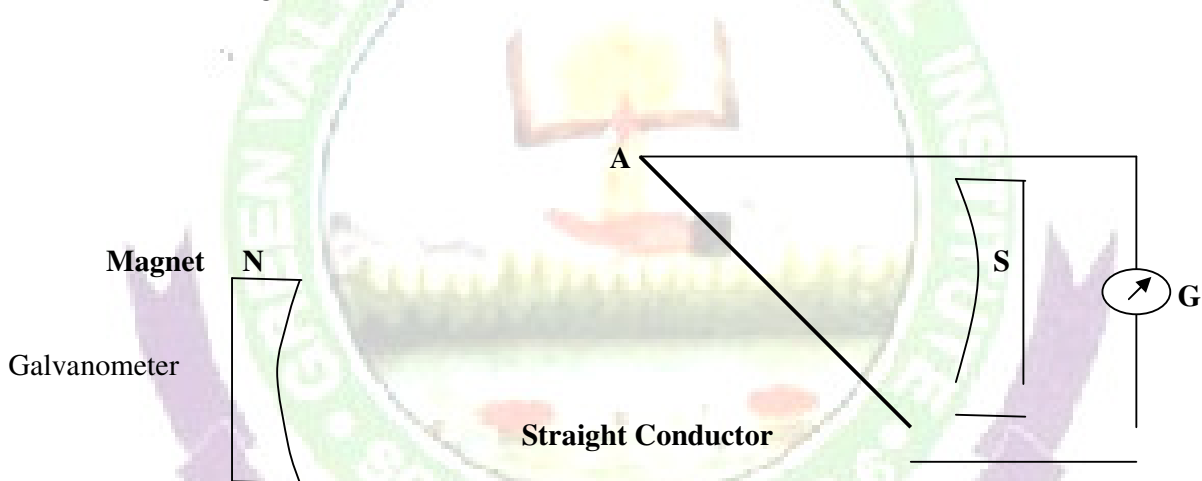

Fleming’s Right Hand Rule: Fleming enunciated a law to show the direction of induced current produced in a straight conductor moving Magnetic Field in a magnetic field. According to this law, “Hold the thumb, the fore finger and the middle finger of your right hand at right angles to one another. Adjust your hand in such a

way, that the fore finger points in the direction of magnetic field, and the thumb points in the direction of motion of the conductor, then the direction in which the middle finger points, gives the direction of the induced current in the conductor”, as shown under. Suppose “AB” is the direction of the magnetic field and “AC” the direction of motion of conductor vertically downwards, then the direction of the induced current will be given by “AD” as per Fleming’s right hand rule, as shown below;

Motor Principle or Force exerted on a current carrying conductor placed in a magnetic field:

Michael Faraday in 1821, performed an experiment to show that when an electric current carrying conductor is placed in a magnetic field, a mechanical force is exerted on the conductor, which can make the conductor move. Thus, experimental observation was referred to as **motor principle** as it forms the working principle of the modern motor. It is also known as **Faraday’s Kicking Wire Experiment**.

Experimental demonstration of motor principle:

Faraday suspended a thick copper wire “AB” vertically from a support “T” by means of a flexible joint “J”. The lower end of the wire is placed just touching the surfaces of mercury kept in shallow vessel “V” placed between the poles of a U-shaped magnet “M”, so that it can move when a force acts on it. The wire is then connected to a battery “B” such that its positive terminal is linked to the end “A” of the wire

and its negative terminal is dipped into the mercury vessel so as to complete the circuit as shown under in the diagram:

On passing electric current through the wire “AB”, the wire is kicked forward towards the south such that its lower end reaches to position “B” as shown by the dotted line. But at this position, its connection with the mercury vessel is cut off due to which circuit is broken and current stops flowing in the wire “AB”. Since no current flows in the wire, no force acts on the wire and it falls back to its original position. But as soon as the wire “AB” comes to its original position and touches the mercury surface, current begins to flow in the wire and the wire is kicked again due to the force exerted by the magnetic field.

Thus, from this experiment, it is clear that when a current carrying conductor is placed in a magnetic field, a mechanical force is exerted on it by the magnetic field. However, reversing the direction of the current flowing in the conductor can reverse the direction of the force exerted.

B A
C D

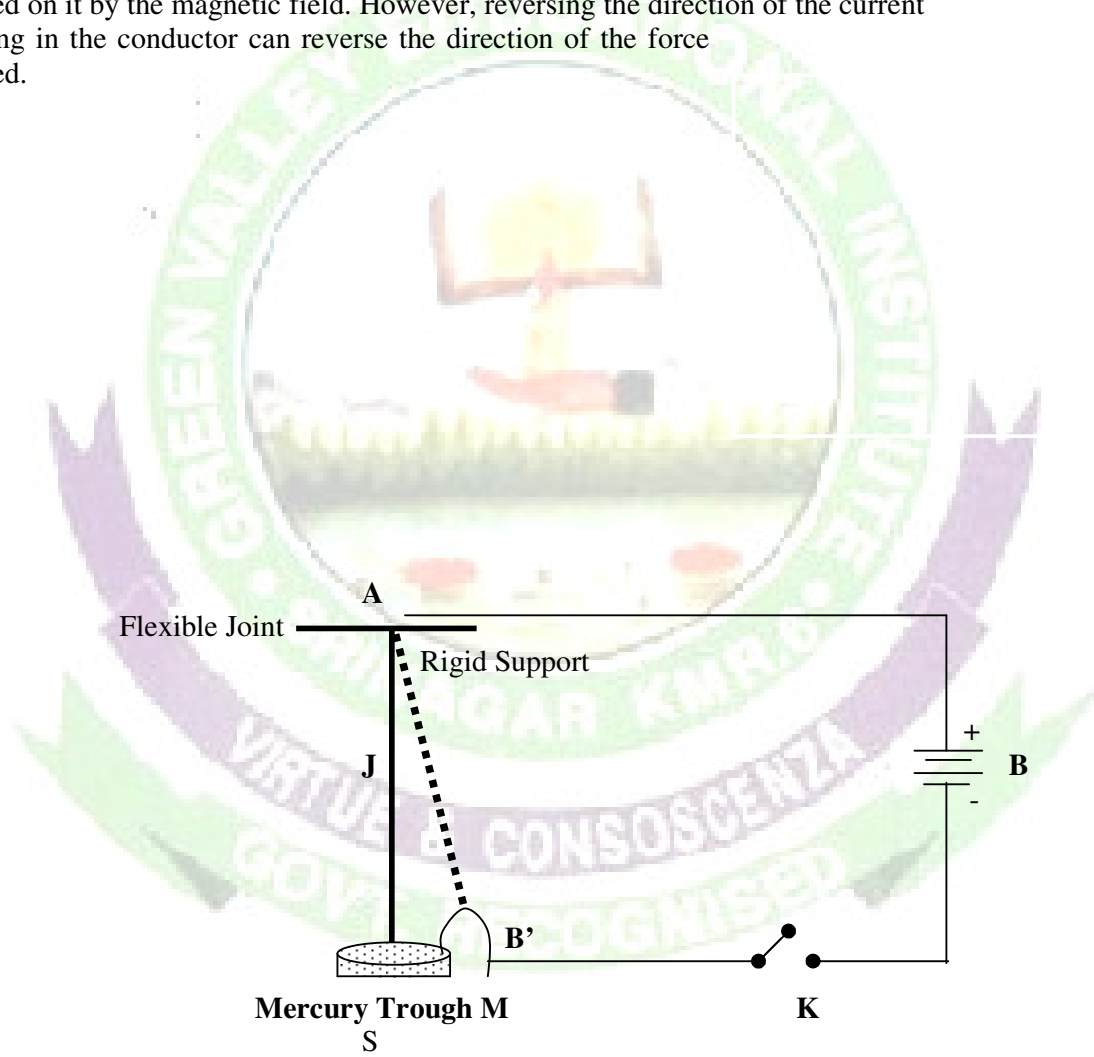

THE ELECTRIC MOTOR

A motor is a device which converts electrical energy into mechanical energy. Every motor has a shaft or spindle which rotates continuously when current is passed into it. The rotation of its shaft is used to drive the various types of machines in homes and industry.

PRINCIPLES OF A MOTOR

An electric motor utilizes the magnetic effect of current. A motor works on the principles' that when a rectangular coil is placed in a magnetic field and current is passed through it's a torque acts on the coil which rotates it continuously.

CONSTRUCTION:- It consists of the following five parts :

1. **Armature :-** the armature $abcd$ consists of a large number of turns of insulated copper wire wound over a soft iron core.
2. **Field magnet :-** the magnetic field (B) is supplied by a permanent magnet NS .
3. **Split-ring or commutator :-** These are two halves of the same metallic ring. The ends of the armature coil are connected to these halves which also rotate with the armature.
4. **Brushes or sliding contacts :-** these are two flexible metal plates or carbon rods B_1 and B_2 which are so fixed that they constantly touch the revolving rings.
5. **Battery :-** the battery consists of a few cells and is connected across the brushes, the brushes pass the current to the rings from where it is carried to the armature.

WORKING OF A MOTOR :

Suppose that initially the coil $ABCD$ is in the horizontal position as shown in figure. On pressing the switch, the current enters the coil through carbon brush P and commutator half ring X . the current flows in the direction $DCBA$ and leaves via ring Y and brush Q .

- (i) In side AB of the coil, the direction of current is from B to A towards south, and the direction magnetic field is from N to S pole towards east. So, by applying Fleming's left hand rule to the side AB of the coil we find that it will experience a force in the upward direction.
- (ii) In side DC of the coil, the direction of current is from D to C towards north but the direction of magnetic field remains the same from N to S pole towards east. So, by applying Fleming's left hand rule to the side DC of the coil, we find that it will experience a force in the downward direction.
- (iii) We find that the force acting on the side AB of the coil is in the upward direction whereas the force acting on the side DC of the coil is in downward direction. These two equal, opposite and parallel forces acting on the two sides of the coil form a couple and rotate the coil in the anticlockwise direction.
- (iv) While rotating, when the coil reaches the vertical position, then the brushes P and Q will touch the gap between the two commutator rings and current to the coil is cut off. Though the current to the coil is cut off when it is in the exact vertical position, the coil does not stop rotating because it has already gained momentum due to which it goes beyond the vertical position.
- (v) When the coil goes beyond the vertical position, the two commutator half rings automatically change contact from one brush to the other. This reverses the direction of current through the coil which, in turn, reverses the direction of forces acting on the two sides of the coil. The side AB of the coil will now be on the left hand side with a downward force on it, whereas side DC of the coil will come on the right hand side with an upward force on it. In this position also a couple acts on the coil which rotates it in the same direction (anticlockwise direction). This process is repeated again and again and the coil continues to rotate as long as the current is passing. This is how an electric motor works. (it should be noted that current in the other two sides, BC and AD , of the rectangular coil is parallel to the direction magnetic field, so no force acts on the side BC and AD of the coil).

USES OF DC MOTORS

1. These are used in electric fans (exhaust, ceiling or table) for cooling and ventilation.
2. These are used for pumping water.
3. Big DC motors are used for running tram-cars.
4. Small DC motors are used in various toys.

1. **D.C Generator (or D.C Dynamo) :**

“D.C. generator” means “Direct Current generator”. That is, a D.C. generator produces direct current and not alternating current.

Construction : A D.C. generator consists of following important parts :

- (i) **Armature.** It consists of a coil $ABCD$ having a large number of insulated copper wires wound over a soft iron core. The coil is called armature. The armature is mounted over the axle which can be rotated by force exerted by steam, blowing wind or falling water.
- (ii) **Field Magnets.** The coil is held between the pole pieces of a strong magnet called the field magnet. In small dynamos, the magnetic field is provided by permanent magnet, in large dynamos, the magnetic field is provided by electromagnets.

- (iii) **Split Rings.** The two ends of the coil are connected to the two copper half rings usually called split rings R_1 and R_2 of commutators.
- (iv) **Carbon Brushes.** Two carbon brushes B_1 and B_2 keep pressing lightly against the two half rings. When the coil is rotating two split rings R_1 and R_2 touch B_1 and B_2 one by one. Current produced can be tapped out.
- (v) **Current from B_1, B_2** are taken out to load connected across two brushes.

Working of a D.C. Generator :

Suppose that the generator coil ABCD is initially in the horizontal position. Again suppose that the coil ABCD is being rotated in the anticlockwise direction between the poles N and S of a horse-shoe type magnet.

- i) As the coil rotates in the anticlockwise direction, the side AB of the coil moves down cutting the magnetic line of force near the N-pole of the magnet, and side DC moves up, cutting the lines of force near the S-pole of the magnetic. Due to this, induced current is produced in the sides AB and DC of the coil. On applying Fleming's right-hand rule to the sides AB and DC of the coil we find that the currents in them are in the directions B to A and D to C respectively. Thus, the induced currents in the two sides of the coil are in the same direction, and we get an effective induced current in the direction BADC. Due to this the brush B_1 becomes a positive (+) pole and brush B_2 becomes negative (-) pole of the generator.
- ii) After half revolution, the sides AB and DC of the coil will interchange their positions : the side AB will come on the right hand side and start moving up whereas side DC will come on the left hand side and start moving down. But when sides of the coil interchange their positions, then the two commutator half rings R_1 and R_2 automatically change their contacts from one carbon brush to the other. Due to this change, the current keeps flowing in the same direction in the outer circuit. The brush B_1 always remaining positive terminal and brush B_2 always remaining negative terminal of the generator. Thus, a D.C. generator supplies a current in one direction by the use of a above discussion we have used the word D.C. generator everywhere. Please note that we can also write D.C. dynamo in place of D.C. generator.

2. A.C. Generator (or A.C. Dynamo) : "A.C. generator" means "Alternating Current generator". That is, an A.C. generator produces alternating current, which alternates (changes) in polarity continuously.

Construction of an A.C. Generator :

A simple A.C. generator consists of the following important parts :

- i) **Armature.** It consists of a coil ABCD having a large number of insulated copper wire wound over a soft iron core . The coil is called an armature. The armature is mounted on an axle which can be rotated by force exerted by falling water, wind or steam.
- ii) **Field Magnet.** The coil is held between the pole-pieces of a strong magnet called the field magnet. In small dynamos, the magnetic field is provided by a permanent magnet but in large dynamos, the magnetic field is provided by electromagnets.
- iii) **Slip Rings.** These consist of two hollow metallic rings R_1 and R_2 mounted on the axle of the coil. The ends of limbs AB and CD of the coil are connected to the rings R_1 and R_2 respectively. These rings rotate along with the rotation of the armature.
- iv) **Brushes.** This consists of metal or carbon plates B_1 and B_2 which lightly touch the rings during the rotation of the armature.
- v) **Current from B_1, B_2** are taken out to load connected across two brushes.

Working of an A.C. Generator :

Suppose that the generator coil ABCD is initially in the horizontal position. Again suppose that the coil ABCD is being rotated in the anticlockwise direction between the poles N and S of a horse-shoe type magnet.

- i) As the coil rotate in the anticlockwise direction, the side AB of the coil moves down cutting the magnetic lines of force near the N-pole of the magnet, and side C moves up, cutting the lines

of force near the S-Pole of the magnet. Due to this, induced current is produced in the sides AB and DC of the coil. On applying Fleming's right-hand rule to the sides AB and DC of the coil we find that the currents are in the direction B to A and D to C, thus, the induced currents in the two sides of the coil are in the same direction, and we get an effective induced current in the direction BADC.

- ii) After half revolution, the sides AB and DC of the coil will interchange their positions. The side AB will come on the right hand side and side DC will come on the left side. So, after half a revolution, side AB starts moving up and side DC starts moving down. As a result of this, the direction of induced current in each side of the coil is reversed after half a revolution. Since the direction of induced current in the coil is reversed after half revolution so the polarity (positive and negative) of the two ends of the coil also changes after half revolution. The end of coil which was positive in the first half of rotation becomes negative in the second half. And the end which was negative in the first half revolution becomes positive in the second half revolution becomes positive in the second half of revolution. Thus, in 1 revolution of the coil, the current changes its direction 2 times.

After every half revolution, each side of the generator coil starts moving in the opposite direction in the magnetic field. The side of the coil which was initially moving downwards in the magnetic field, after half revolution, it starts moving in opposite direction – upwards. Similarly, the side of coil which was initially moving upwards, after half revolution, it starts moving downwards. Due to the change in the direction of motion of the two sides of the coil in the magnetic field after every half revolution, the direction of current produced in them also changes after every half revolution.

EARTHING: Electric appliances such as ovens, table fans, toasters etc. are frequently touched by us with bare hands. If by chance the insulation of any such appliances melts or is damaged somehow, such that its bare wire touches its metal casing, then the person will receive a severe electric shock. It is because the electric potential of the metal casing will be the same as that of the applied potential. Thus, the electric current will rush through our body to earth and in doing so, will affect our nervous system which in turn may cause death. To avoid such a situation, metal casing of all such appliances are **earthed**. It means that the metal body of the appliance is connected to a thick copper wire, which is buried deep in the earth and its end is a copper plate surrounded by a mixture of charcoal and common salt.

The earth can be regarded as an **electric sink** i.e. it can receive any amount of electrons, but **potential remains zero**. Thus when an earthed appliance gets short circuited, then the current from its metal body flows into the earth. Since earth doesn't offer any resistance, therefore, the **magnitude of the current in a short-circuited appliance suddenly rises to a very high value**. This rise in magnitude of the current in turn **overloads the circuit and hence the fuse in that circuit melts**. On melting of fuse, the short-circuited appliance will not receive any current and hence user is protected from receiving an electric shock. Moreover, the appliance itself is protected from burn out.

COLOUR CODING OF ELECTRIC WIRES: An electric appliance is provided with three core flexible cable. In order to distinguish, which wire is live or neutral or of earth, the insulation of each wire is given a specific colour.

The old convention of colour is **red** for **live wire**, **black** for **neutral wire** and **green** for **earth wire**.

However, according to the new international convention, **brown** is for **live wire**, **light blue** for the **neutral wire** and **green or yellow** for **earth wire**.

The three cores flexible wires can withstand current of some specific value it can tolerate, then the plastic insulation on them melts. This in turn brings the wires in contact and hence an electric short circuit results.

SHORT – CIRCUITING:

In general, **short – circuiting occurs when the ends of a circuit are connected by a conductor of very low resistance as compared to that of the circuit**. In household connections, short-circuiting occurs when the live (positive) wire and the neutral (negative) wire come in direct contact with each other, this happens due to (i) damage to the insulation of the power – lines (ii) a fault in an electric appliance due to which current does not pass through it. On account of short-circuiting, resistance of the circuit decreases to a very small

value and consequently the current becomes very large. This large current results in heating of live wires which produces sparking at the point of short-circuiting. This sparking sometimes causes fire in a building.

End.....

